

## Z20 MINI-SPLIT CONDENSATE PUMP

### Submittal Information

Part No.	18101
Document No.	SPEC18101
Date	2025-02-05
Revision	01

### General Properties

- Power supply: 100-240V AC 50/60Hz <4W
- Max.flow: 18L(4.76 gal)/H, range from 12-18L(3.17-4.76 gal)/H
- Max.recommended head: 12m (39.37 ft)
- Max.suction lift: 2m (6.56 ft)
- Max.unit output: 16KW / 54,600 Btu/h
- Max.water temperature: 40°C (104°F)
- Discharge tube: 6mm (1/4 in) ID
- Class: II appliance
- Protection: Fully potted, IP-45

### Specification

Item No.	Description	Std. Pkg	U/M
18101	Z20 Mini-split Pump, Upgrade Sensor, Dual Vol, 5.3 GPH	1	EA

### Features

- The pump operates with low noise, ensuring a quiet environment.
- It uses a capacitive sensor for safe and reliable water detection.
- Large flow capacity allows efficient drainage of condensate water.
- Automatic flow adjustment minimizes noise and extends pump lifespan.
- The design enables convenient cleaning and maintenance.



### Accessories List

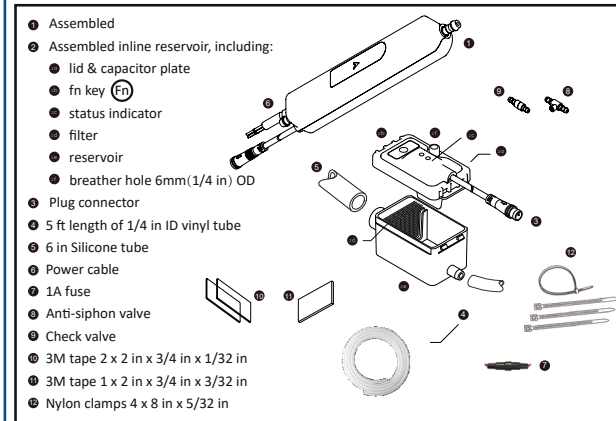

### Performance Data

