

X40H MINI-SPLIT CONDENSATE PUMP

Submittal Information

Part No.	18123
Document No.	SPEC18123
Date	2025-02-05
Revision	01

General Properties

- Power supply: 100-240V AC 50/60Hz <4W
- Max.flow: 40L(10.56 gal)/H @ 0 head
- Sound level: <19dB(A) @ 1m (3.28 ft)
- Water storage: 230ml (7.78 oz)
- Max.recommended head: 20m (65.62 ft)
- Max.unit output: 46KW / 157,000 Btu/h
- Safety switch: 3A Normally closed
- Max.water temperature: 70°C (158°F)
- Discharge tube: 6mm (1/4 in) ID
- Class: II appliance
- Rated: Continuous
- IP Protection: IPX5
- Fully potted: ✓

Specification

Item No.	Description	Std. Pkg	U/M
18123	X40H Mini-split Pump, Dual Vol, 10.6 GPH	1	EA

Features

- Safety and reliability.
- Its clean and aesthetic design ensures compatibility with condensation units.
- Typically installed below mini splits for efficient operation.
- Operates with a float switch mechanism to detect water presence.
- Provides powerful drainage of condensate water while maintaining a silent environment.



Accessories List

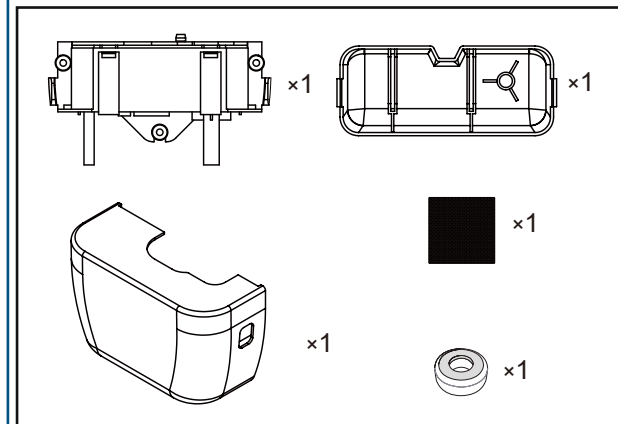

Performance Data

